

# VX Series

## Diesel and LP Gas Forklift Trucks

8,000kg and 9,000kg



- Intellix Vehicle System Manager
- Canbus technology
- Techtronix 332 Series transmission
- Oil Immersed Brakes
- Yale Accutouch Mini Lever Module
- On-board Diagnostics

**Yale**   
People. Products. Productivity.™

# Truck Dimensions

If  $b_{12/2} \leq b_{13}$   
 $Ast = Wa + x + l_6 + a$   
 If  $b_{12/2} > b_{13}$   
 $Ast = Wa + R + a = Wa + \sqrt{(l_6 + x)^2 + (b_{12/2} - b_{13})^2} + a$

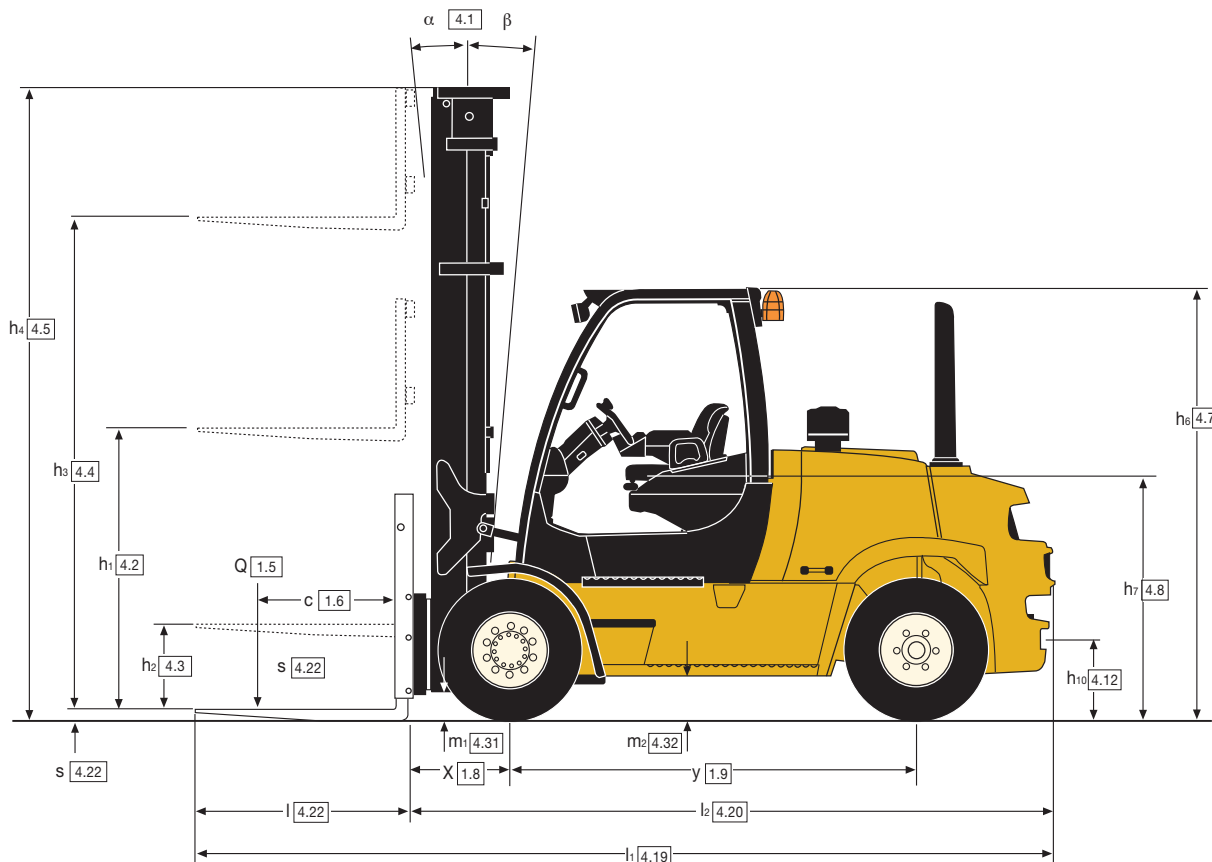
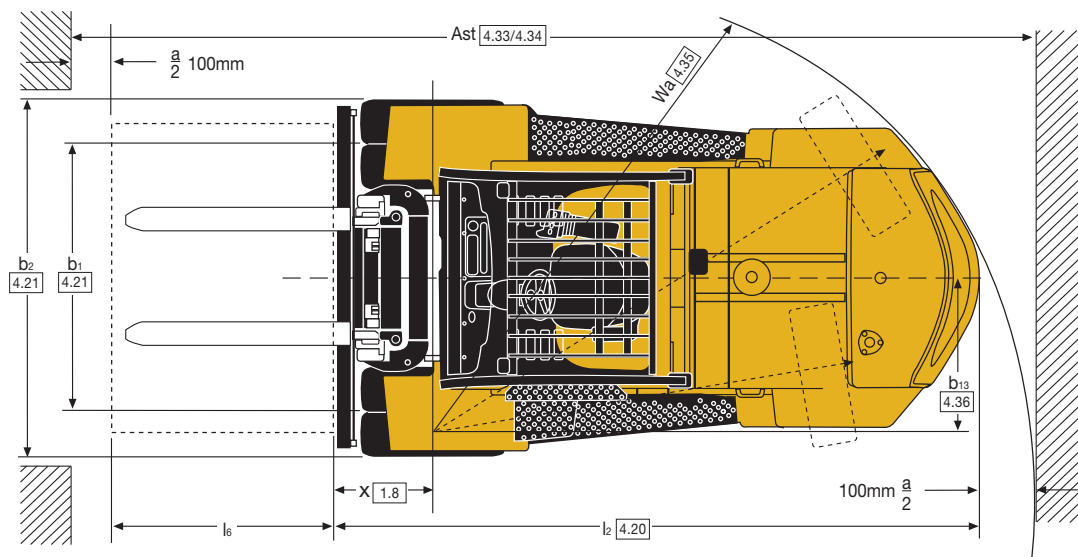

## GDP/GLP 80VX6 Dual Drive mast details and capacity ratings (kg)

Model							GDP/GLP 80VX6					
Tyres							Dual Drive Wheel		Dual Drive Wheel		Dual Drive Wheel	
Width across tyres							with carriage		with carriage + sideshift		with carriage + sideshifting fork postioner	
Masts	OAH h1	FFH h2+s	MFH h3+s	h4	Tilt		600mm Load Centre		600mm Load Centre		600mm Load Centre	
					F	B	Capacity at max. height (kg)	Capacity to lift height (kg to mm)	Capacity at max. height (kg)	Capacity to lift height (kg to mm)	Capacity at max. height (kg)	Capacity to lift height (kg to mm)
2 Stage LFL (V)	2712	-	3065	4225	5	9	8000	-	7580	-	7530	-
	2962	-	3565	4725	5	9	8000	-	7570	-	7520	-
	3462	-	4565	5725	5	9	8000	-	7540	-	7500	-
	3962	-	5565	6725	5	9	8000	-	7520	-	7470	-
	4212	-	6065	7225	5	9	7710	8000 to 5815	7240	7510 to 5815	7200	7460 to 5815
3 Stage FFL (E)	2702	1565	4615	5952	5	6	8000	-	7560	-	7530	-
	3002	1865	5515	6852	5	6	8000	-	7540	-	7510	-
	3152	2015	5965	7302	5	6	7940	8000 to 5915	7480	7530 to 5915	7450	7500 to 5915

## GDP/GLP 80VX9 Dual Drive mast details and capacity ratings (kg) - Pneumatic tyres

Model							GDP/GLP 80VX9					
Tyres							Dual Drive Wheel		Dual Drive Wheel		Dual Drive Wheel	
Width across tyres							with carriage		with carriage + sideshift		with carriage + sideshifting fork postioner	
Masts	OAH h1	FFH h2+s	MFH h3+s	h4	Tilt		900mm Load Centre		900mm Load Centre		900mm Load Centre	
					F	B	Capacity at max. height (kg)	Capacity to lift height (kg to mm)	Capacity at max. height (kg)	Capacity to lift height (kg to mm)	Capacity at max. height (kg)	Capacity to lift height (kg to mm)
2 Stage LFL (V)	2712	-	3065	4398	5	9	8000	-	7580	-	7550	-
	2962	-	3565	4898	5	9	8000	-	7560	-	7530	-
	3462	-	4565	5898	5	9	8000	-	7530	-	7500	-
	3962	-	5565	6898	5	9	7920	8000 to 5265	7420	7500 to 5265	7390	7460 to 5265
	4212	-	6065	7398	5	9	7770	8000 to 5265	7270	7480 to 5265	7240	7440 to 5265
3 Stage FFL (E)	2702	1405	4615	5952	5	6	8000	-	7560	-	7530	-
	3002	1705	5515	6852	5	6	7770	8000 to 5365	7320	7530 to 4615	7290	7500 to 6515
	3152	1855	5965	7302	5	6	7650	8000 to 5365	7180	7510 to 4615	7150	7480 to 4615

## GDP/GLP 90VX6 Dual Drive mast details and capacity ratings (kg) - Pneumatic tyres

Model							GDP/GLP 90VX6					
Tyres							Dual Drive Wheel		Dual Drive Wheel		Dual Drive Wheel	
Width across tyres							with carriage		with carriage + sideshift		with carriage + sideshifting fork postioner	
Masts	OAH h1	FFH h2+s	MFH h3+s	h4	Tilt		600mm Load Centre		600mm Load Centre		600mm Load Centre	
					F	B	Capacity at max. height (kg)	Capacity to lift height (kg to mm)	Capacity at max. height (kg)	Capacity to lift height (kg to mm)	Capacity at max. height (kg)	Capacity to lift height (kg to mm)
2 Stage LFL (V)	2712	-	3065	4225	5	9	9000	-	8500	-	8460	-
	2962	-	3565	4725	5	9	9000	-	8490	-	8440	-
	3462	-	4565	5725	5	9	9000	-	8470	-	8420	-
	3962	-	5565	6725	5	9	8720	9000 to 5315	8190	8450 to 5315	8140	8400 to 5315
	4212	-	6065	7225	5	9	8120	9000 to 5315	7620	8440 to 5315	7570	8390 to 5315
3 Stage FFL (E)	2702	1565	4615	5952	5	6	9000	-	8500	-	8470	-
	3002	1865	5515	6852	5	6	8830	9000 to 5365	8320	8480 to 5365	8290	8450 to 5365
	3152	2015	5965	7302	5	6	8300	9000 to 5365	7810	8470 to 5365	7780	8430 to 5365

### Rated Load vs. Load Center

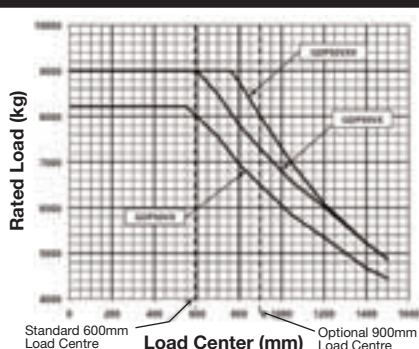

#### Truck Configuration

2-stage LFL F80 mast at HNHL (5565mm MFH) 80VX6 models.  
 2-stage LFL F80 mast at HNHL (5315mm MFH) 90VX6 models.  
 2-stage LFL F90 mast at HNHL (5065mm MFH) 80VX9 models.

2030mm STANDARD HOOK CARRIAGE WITH LOAD BACKREST

**Basic Truck:** DSL with 3-speed basic transmission and Overhead Guard solid Pneumatic tyres.

**The ratings are computed using fork lengths as below:**

	Load Centre (mm)	Fork length (mm)
All models	500 to 700	1200
	Over 700 to 1000	1500
	Over 1000 to 1200	1800
	Over 1220	2400

#### Note:

Special forks with higher load ratings are required to obtain full truck ratings on load centers greater than 1000mm on GDP/GLP 80VX9 and greater than 1300mm on GDP/GLP 90VX6.

# VDI 2198 - General Specifications

		Yale				Yale					
		GDP 80 VX6				GDP 80 VX6					
Distinguishing mark	1.1	Manufacturer (abbreviation)									
	1.2	Manufacturer's type designation									
		Engine/Transmission	Cummins 3.3L Techtronix 332		Kubota 3.8L Techtronix 332 / Techtronix 332+		Cummins 3.3L Techtronix 332				
		Model	Base		Value / Productivity		Base				
		Brake Type	Oil Immersed		Oil Immersed		Oil Immersed				
	1.3	Drive: electric (battery or mains), diesel, petrol, LPG	Diesel		Diesel		Diesel				
	1.4	Operator type: hand, pedestrian, standing, seated, orderpicker	Seat		Seat		Seat				
	1.5	Rated capacity/rated load	Q (kg)	8000		8000		8000			
	1.6	Load centre distance	c (mm)	600		600		900			
1.8	Load distance, centre of drive axle to fork	x (mm)	613.5		664.5		613.5				
1.9	Wheelbase	y (mm)	2450		2450		2450				
Weights	2.1	Service weight (w/ std equipment: mast, carriage, forks, etc.)	kg	11259		11259		12169			
	2.2	Axle loading, laden front/rear	kg	17416	1844	17416	1844	18418	1751		
	2.3	Axle loading, unladen front/rear	kg	5453	5806	5453	5806	5310	6859		
Tyres/chassis	3.1	Tyres: P=pneumatic, C=cushion, SC=supercushion	P				P				
	3.2	Tyre size, front	8.25x15 14PR <sup>1</sup>		8.25x15 14PR <sup>1</sup>		8.25x15 14PR <sup>1</sup>				
	3.3	Tyre size, rear	8.25x15 14PR <sup>1</sup>		8.25x15 14PR <sup>1</sup>		8.25x15 14PR <sup>1</sup>				
	3.5	Number of wheels, front/rear (x = driven wheels)	4X / 2 <sup>1</sup>		4X / 2 <sup>1</sup>		4X / 2 <sup>1</sup>				
	3.6	Tread, front	b10 (mm)	2003		2003		2003			
	3.7	Tread, rear	b11 (mm)	1535.6		1535.6		1535.6			
	Dimensions	4.1	Tilt of mast/fork carriage, forward $\alpha$ / backward $\beta$	$\alpha$ / $\beta$ (°)	5 / 9°		5 / 9°		5 / 9°		
4.2		Height, mast lowered	h1 (mm)	3962		3962		3462			
4.3		Free lift ▲	h2 (mm)	0		0		0			
4.4		Lift ▲	h3 (mm)	5500	5565	5500	5565	4500	4565		
4.5		Height, mast extended +	h4 (mm)	6725		6725		5898			
4.7		Height of overhead guard (cabin) ○	h6 (mm)	2531		2531		2531			
4.7.1		Cab height (open cab)	mm	2549		2549		2549			
4.8		Seat height/stand height ✕	h7 (mm)	1540		1540		1540			
4.12		Coupling height	h10 (mm)	476		476		476			
4.19		Overall length	l1 (mm)	5096.5		5096.5		5238			
4.20		Length to face of forks	l2 (mm)	3896.5		3896.5		4089			
4.21		Overall width	b1/b2 (mm)	2239		2239		2239			
4.22		Fork dimensions	s/e/l (mm)	65 x 200 x 1200		65 x 200 x 1200		65 x 200 x 1800			
4.23		Fork carriage DIN 15173, class/type A/B		IVA		IVA		IVA			
4.24		Fork carriage width ▶	b3 (mm)	2030 <sup>3</sup>		2030 <sup>3</sup>		2030 <sup>3</sup>			
4.31		Ground clearance, laden, below mast	m1 (mm)	173		173		173			
4.32		Ground clearance, centre of wheelbase	m2 (mm)	253		253		253			
4.33	Aisle width with pallets 1000mm long x 1200mm wide	Ast (mm)	5486.5		5486.5		5658.5				
4.34	Aisle width with pallets 800mm wide x 1200mm long	Ast (mm)	5686.5		5686.5		5858.5				
4.35	Turning radius (outer)	Wa (mm)	3673		3673		3794				
4.36	Inner turning radius	b13 (mm)	1482		1482		1482				
4.41	90° intersecting aisle (With pallet W = 1200mm, L = 1000mm)	mm	3045		3045		3150				
4.42	Step Height (from ground to running board)	mm	321		321		321				
4.43	Step Height (between intermediate steps between running board and floor)	mm	256		256		256				
Performance data	5.1	Travel speed laden/unladen	km/h								
		Stage IIIA diesel engine	km/h	23.2	23.8			23.2	23.8		
		Stage IIIB diesel engine	km/h			23.2	23.8				
	5.2	Lift speed, laden/unladen (2LFL)	m/sec	0.43	0.45	0.43	0.45	0.42	0.45		
	5.3	Lowering speed, laden/unladen (2LFL)	m/sec	0.41	0.37	0.41	0.37	0.41	0.37		
	5.5	Drawbar pull, laden/unladen @ 1.6 km/h	kN								
		Stage IIIA diesel engine	kN	53.4	32.2			53.4	30.6		
		Stage IIIB diesel engine	kN			53.4	32.2				
	5.7	Gradeability, laden/unladen @ 1.6 km/h	%								
		Stage IIIA diesel engine	%	29.5	30.5			28.1	26.6		
	Stage IIIB diesel engine	%			29.5	30.5					
5.10	Service brake		Hydraulic		Hydraulic		Hydraulic				
Combustion-engine	7.1	Engine manufacturer/type	Cummins QSB3.3		Kubota 3.8L		Cummins QSB3.3				
	7.2	Engine power according to ISO1585	kW	82 @ 2400		82 @ 2400		82 @ 2400			
	7.3	Rated speed at max. power	rpm	2430		2400		2430			
	7.4	Number of cylinders/displacement	cm3	4 / 3261		4 / 3769		4 / 3261			
	7.5	Fuel consumption according VDI cycle	l/hr	9.4		9.1		9.8			
Addition data	8.1	Type of drive control	Electronically Controlled Powershift		Electronically Controlled Powershift		Electronically Controlled Powershift				
	8.2	Operating pressure for attachments (nominal relief pressure)	bar	155		155		155			
	8.3	Oil volume for attachments (nominal) †	l/min	93		93		93			
	8.4	Sound level at driver's ear according DIN 12053 (without / with cab) ★	dB(A)	79 / 79		79 / 79		79 / 79			
		Guaranteed sound power 2001/14/EC	dB	106		106		106			
	8.5	Towing coupling, type DIN		Pin		Pin		Pin			
	8.7	Hydraulic oil tank, capacity (drain & refill)	litres	70.9		70.9		70.9			
	8.8	Fuel tank, capacity (Diesel)	litres	74.8		74.8		74.8			

★ Measured according to the test cycles and based on the weighting values contained in EN12053.

† Variable

▲ Bottom of Forks / Top of forks

✕ Full suspension seat in depressed position

▶ Add 50mm with load backrest

○ h6 subject to +/- 5mm tolerance.

○ 2549mm for Cab option.

✚ Without load backrest.

**Spec sheet 80VX6 truck based on :-**  
5500mm Bottom of Forks / 5565mm Top of Forks F80 2 stage LFL mast with 2030mm standard carriage, 1200mm forks.

Model		Yale				Yale		Yale		Yale		1.1	
80VX9		GDP 90 VX6				GLP 80 VX6		GLP 80 VX9		GLP 90 VX6		1.2	
Kubota 3.8L Techtronix 332 / Techtronix 332+		Cummins 3.3L Techtronix 332		Kubota 3.8L Techtronix 332 / Techtronix 332+		GM 5.7L Techtronix 332 / Techtronix 332+		GM 5.7L Techtronix 332 / Techtronix 332+		GM 5.7L Techtronix 332 / Techtronix 332+			
Value / Productivity		Base		Value / Productivity		Value / Productivity		Value / Productivity		Value / Productivity			
Oil Immersed		Oil Immersed		Oil Immersed		Oil Immersed		Oil Immersed		Oil Immersed			
Diesel		Diesel		Diesel		LPG		LPG		LPG		1.3	
Seat		Seat		Seat		Seat		Seat		Seat		1.4	
8000		9000		9000		8000		8000		9000		1.5	
900		600		600		600		900		600		1.6	
664.5		613.5		613.5		613.5		664.5		613.5		1.8	
2450		2450		2450		2450		2450		2450		1.9	
12169		11624		11624		11340		12250		11705		2.1	
18418	1751	18762	1967	18762	1967	17434	1907	18436	1814	18664	2041	2.2	
5310	6859	5304	6424	5304	6424	5471	5869	5328	6922	5206	6499	2.3	
P		P		P		P		P		P		3.1	
8.25x15 14PR <sup>1</sup>		8.25x15 14PR <sup>1</sup>		8.25x15 14PR <sup>1</sup>		8.25x15 14PR <sup>1</sup>		8.25x15 14PR <sup>1</sup>		8.25x15 14PR <sup>1</sup>		3.2	
8.25x15 14PR <sup>1</sup>		8.25x15 14PR <sup>1</sup>		8.25x15 14PR <sup>1</sup>		8.25x15 14PR <sup>1</sup>		8.25x15 14PR <sup>1</sup>		8.25x15 14PR <sup>1</sup>		3.3	
4X / 2'		4X / 2'		4X / 2'		4X / 2'		4X / 2'		4X / 2'		3.5	
2003		2003		2003		2003		2003		2003		3.6	
1535.6		1535.6		1535.6		1535.6		1535.6		1535.6		3.7	
5 / 9°		5 / 9°		5 / 9°		5 / 9°		5 / 9°		5 / 9°		4.1	
3462		3462		3462		3962		3462		3462		4.2	
0		0		0		0		0		0		4.3	
4500	4565	4500	4565	4500	4565	5500	5565	4500	4565	4500	4565	4.4	
5898		5725		5725		6725		5725		5725		4.5	
2531		2531		2531		2531		2531		2531		4.7	
2549		2549		2549		2549		2549		2549		4.7.1	
1540		1540		1540		1540		1540		1540		4.8	
476		476		476		476		476		476		4.12	
5238		5158.1		5158.1		5096.5		5238		5158.1		4.19	
4089		3958.1		3958.1		3896.5		4089		3958.1		4.20	
2239		2239		2239		2239		2239		2239		4.21	
65 x 200 x 1800		65 x 200 x 1200		65 x 200 x 1200		65 x 200 x 1200		65 x 200 x 1800		65 x 200 x 1200		4.22	
IVA		IVA		IVA		IVA		IVA		IVA		4.23	
2030 <sup>3</sup>		2030 <sup>3</sup>		2030 <sup>3</sup>		2030 <sup>3</sup>		2030 <sup>3</sup>		2030 <sup>3</sup>		4.24	
173		173		173		173		173		173		4.31	
253		253		253		253		253		253		4.32	
5658.5		5536.5		5536.5		5486.5		5658.5		5536.5		4.33	
5858.5		5736.5		5736.5		5686.5		5858.5		5736.5		4.34	
3794		3723		3723		3673		3794		3723		4.35	
1482		1482		1482		1482		1482		1482		4.36	
3150		3074		3074		3045		3150		3074		4.41	
321		321		321		321		321		321		4.42	
256		256		256		256		256		256		4.43	
		23.2		23.8		22.9		23.5		22.9		23.5	5.1
23.2		23.8		23.2		23.8							
0.42		0.45		0.42		0.45		0.35		0.42		5.2	
0.41		0.37		0.41		0.37		0.41		0.37		5.3	
						53		32		53		31	5.5
53.4		30.6		53.4		30.6							
		27.2		28.4		30		31		28		27	5.7
28.1		26.6		27.2		28.4							
Hydraulic		Hydraulic		Hydraulic		Hydraulic		Hydraulic		Hydraulic		5.10	
Kubota 3.8L		Cummins QSB3.3		Kubota 3.8L		GM 5.7L		GM 5.7L		GM 5.7L		7.1	
82 @ 2400		82 @ 2400		82 @ 2400		97 @ 2400		97 @ 2400		97 @ 2400		7.2	
2400		2430		2400		2400		2400		2400		7.3	
4 / 3769		4 / 3261		4 / 3769		8 / 5735		8 / 5735		8 / 5735		7.4	
9.4		10.4		9.8		19.8		10.1		20.8		10.6	7.5
Electronically Controlled Powershift		Electronically Controlled Powershift		Electronically Controlled Powershift		Electronically Controlled Powershift		Electronically Controlled Powershift		Electronically Controlled Powershift		8.1	
155		155		155		155		155		155		8.2	
93		93		93		93		93		93		8.3	
79 / 79		79 / 79		79 / 79		82 / 79		82 / 79		82 / 79		8.4	
106		106		105		107		107		107			
Pin		Pin		Pin		Pin		Pin		Pin		8.5	
70.9		70.9		70.9		70.9		70.9		70.9		8.7	
74.8		74.8		74.8								8.8	

Distinguishing mark

Weights

Tyres/chassis

Dimensions

Performance data

Combustion-engine

Addition data

**Spec sheet 80VX9 truck based on :-**  
4500mm Bottom of Forks / 4565mm Top of Forks F90 2 stage LFL mast with 2030mm standard carriage, 1800mm forks.

**Spec sheet 90VX6 truck based on :-**  
4500mm Bottom of Forks / 4565mm Top of Forks F80 2 stage LFL mast with 2030mm standard carriage, 1200mm forks.

**Notes:** 1 - Other tyre options are available  
2 - Backtilt limited to 6° with some mast options  
3 - Carriage is 2030mm wide, load backrest is 2080mm wide.

Single tyre option requires application survey special quotation to be submitted to SPED for approval prior to order.



## VX Series

Models: GDP/GLP 80VX6, 80VX9, 90VX6

### Yale Veracitor VX Series

This series of trucks is designed to provide excellent performance and is optimized for lowest hourly cost of operation. An active regenerating Diesel particulate filter significantly reduces the number of services interventions. DPF performance is constantly monitored and displayed on supplemental display at operator eye level.

### Diesel Engines

The Yale Veracitor Cummins QSB3.3L diesel turbo charged engine featuring legendary Cummins reliability is offered for the Veracitor Base model and is available for unregulated markets. The Yale Veracitor Value and Productivity models feature new Stage IIIB compatible Kubota V3800 E4 3.8L diesel engine or GM 5.7L V8 LPG engine for regulated markets.

### Low emission engines from Kubota

The Stage IIIB Kubota V3800 E4 3.8L (82 kW@2200rpm) diesel engine meets the stringent emissions regulations by using a number of technologies including cooled exhaust gas recirculation, charge air cooling and an active regenerating Diesel particulate filter (DPF) which reduces soot levels by 90% to 0.025g/kWh.

**Stage IIIB** = High productivity and low emissions. You can recognize a low emission trucks by the Stage IIIB symbol.



**NOTE:** A Stage IIIB engine must run on Ultra Low Sulphur Diesel (ULSD) fuel, with a maximum of 15 ppm sulphur content. Diesel fuel with a higher sulphur content than 15ppm will compromise the emissions performance of the Stage IIIB engine and may result in damage to components.

### LPG Engines

The Yale Veracitor VX GM Vortec™ V8 engine features a rigid cast iron block and main bearing caps. The Nodular iron crankshaft is supported on four main bearings with a cast iron camshaft. Hydraulic valve lifters are utilized to eliminate the need for manual adjustment. The GM engines also feature an electronic throttle for precise performance and control.

### Fuel System

The GM LPG engine uses a mixer system. The system uses a vaporizer built into the electronic pressure regulator to convert the fuel from a liquid to a gas and then precisely

## Engine Specifications

### LPG Engine Specification

Engine	GM
Cylinders	V8
Displacement	5.7 litre
Power	98 kW @ 2,400rpm
Torque	422 Nm @ 1,500rpm

### Stage IIIA Diesel Engine Specification

Engine	Cummins
Cylinders	Inline 4
Displacement	3.3 litre
Power	82 kW @ 2,400rpm
Torque	415 Nm @ 1,400rpm

### Stage IIIB Diesel Engine Specification

Engine	Kubota
Cylinders	Inline 4
Displacement	3.8 litre
Power	82 kW @ 2,400rpm
Torque	371 Nm @ 1,400rpm

deliver the proper amount to the mixer via the electronic pressure regulator. An electronic throttle body regulates the fuel/air mixture to the intake manifold. The Engine Control Unit controls the electronic throttle body, electronic pressure regulator and spark advance to provide the necessary torque. The Engine Control Unit's inputs include manifold absolute pressure, intake air temperature, engine coolant temperature, engine oil pressure, accelerator pedal position, throttle position, engine speed, camshaft position, plus pre and post catalyst oxygen sensor signals.

### Transmissions

#### Techtronix 332 transmission

The standard Techtronix 332 transmission features three speeds forward and two speeds in reverse for excellent gradeability and drawbar pull while allowing top travel speeds for maximum productivity. First gear also offers increased drawbar pull for use on gradients. Whilst second and third gears provide maximum engine efficiency in applications where longer travel distances are common.

#### Auto Deceleration (ADS)

This is achieved through the controlled application of the clutch packs to slow the truck down without the need to apply the foot brake.

#### Controlled Power Reversal (CPR)

Tyre spin is significantly reduced by precisely regulating engine speed

during full power reversal situations. Tyre wear is proportionally decreased, reducing the number of replacement tyres required.

#### Controlled Roll Back (CRB)

Roll back on gradients is limited to 75mm per second making load spotting and discharging of loads on ramps and gradients easier and more efficient.

#### Techtronix 332+ Transmission

The Techtronix 332+ has all the standard Techtronix 332 transmission features plus Dynamic Auto Deceleration System (DADS) and Auto Speed Hydraulics (ASH) with Automatic Inching Control which automatically increases engine RPM as hydraulic functions are actuated, while maintaining control over vehicle speed. The Throttle Response Management feature (TRM) provides travel speed as a direct result of pedal position, improving truck control.

A 100 mesh suction and 10 micron return line filtration system protect the transmission from abrasive contaminants.

#### Auto-Speed Hydraulics (ASH) with Automatic Inching Control

When lifting a load, the engine speed is automatically increased to provide full hydraulic power. The Intelix VSM™ maintains the travel speed (or prevents travel) until the operator activates the accelerator. No operator inching is required and productivity is increased by simplifying operator actions.

#### Throttle Response Management (TRM)

This feature allows the operator to manage his travel speed, according to the position of his foot on the accelerator pedal. For example, travel speed can be maintained both on the level and on a gradient, without the need to depress the pedal further. The system also compensates for hydraulic operation and drawbar pull.

#### Dynamic Auto Deceleration System (DADS)

This allows the operator to reduce the speed of the truck without using the brake. The rate of braking is determined by the programmable dashboard settings 1-10. The rate of deceleration can be controlled further by the rate at which the operator releases his foot from the accelerator pedal.

## VX Series

Models: GDP/GLP 80VX6, 80VX9, 90VX6

The transmission also features electronic shift control, smooth electronic inching, neutral start switch, and anti-restart protection. A single pedal controls both inching and braking.

Optional dual inch/brake pedals are available for operators who prefer this design.

### Cooling System

The modular radiator system incorporates sections for engine coolant, transmission oil and engine intake air. A 500mm diameter blade pusher-type fan provides cooling airflow. A permanently lubricated water pump and a high capacity, cross-flow radiator ensure rapid heat dissipation. The sealed cooling system operates at a pressure of 1.0 bar and includes a coolant recovery tank for visual inspection of coolant level. The radiator is soft-mounted for durability.

### Drive Axle

The drive axles are designed to withstand heavy loads and absorb shocks. The wheel hubs rotate on large tapered roller bearings. The drive shaft transmits rotational torque to the drive axle from the engine and transmission. Transmission torque is distributed through planetary gear reduction and an industrial hypoid ring gear and pinion differential assembly.

The drive axle is a "self contained" assembly that is isolated from the transmission by the drive shaft and heavy-duty rubber isolators. The axle shafts utilise a "rolled fillet" root spline design for increased resistance to torsion stress. A magnetic sump plug is used to collect any metal particles that are circulating in the axle oil, preventing component wear.

### Brakes

Oil immersed disc brakes are standard and internal to the axle for environmental protection. The low pedal effort brakes require no adjustment and very little maintenance, yet provide an extremely long service life.

Metered hydraulic oil pressure is used to actuate the oil immersed disc brakes via a brake-pedal actuated modulating valve. This system yields consistent pedal travel for optimum control. The independent, hand adjustable parking brake with push-

button release has an audible alarm to indicate when the operator has left the truck without applying the park brake.

### Steering

Hydraulic Power Steering (hydrostatic steering) provides responsive control and eliminates mechanical linkages for reduced surface shock and simplified maintenance. The steering wheel is 30cm in diameter with a textured surface grip and spinner knob, and requires only four turns lock-to-lock. The center mounted steer cylinder is located within the confines of the steer axle for protection.

### Steer Axle

The steer axle is constructed of cast ductile steel and is mounted on phenolic bushings, allowing excellent stability and axle articulation. The steer axle system features tapered spindle bearings and non-adjustable tie rod end for durability.

### Chassis

The chassis designed by state-of-the-art finite element methods features 25mm thick frame members and contains a rugged, unitised frame structure with a low step for simple entrance to the operator's compartment. The ergonomically designed overhead guard is bar type for excellent visibility and reduced noise. Gull wing doors on both right and left sides provide excellent access.

### Operator's Compartment

The operator's compartment features Yale Accutouch minilever electro-hydraulic controls integrated into the operator's right-side armrest providing superior ergonomics. The automotive-style pedal arrangement has a large, single inch/brake pedal as standard. Rubber floor mats reduce noise and vibration. The floorplate can be removed without tools for excellent service access. Low step height and convenient hand grips provide easy entry and exit to and from the truck and superior reverse driving position.

**Intellix Vehicle System Manager** This is the master truck controller, providing extensive monitoring and control of truck functions and systems. CANbus technology reduces wiring complexity and enables comprehensive communications between truck systems. The



ergonomically positioned dash display transmits continual feedback to the operator and allows for communication of service codes. Comprehensive on-board diagnostics enable quick and easy troubleshooting. The electrical system features sealed connectors and 'Hall Effect' sensors for superior dependability.

### Hydraulic System

The hydraulic system incorporates a gear type pump with a cast iron body for quiet efficiency. The system is protected from overloads by a main relief valve for the lift circuit and a secondary relief valve for tilt and auxiliary functions. Oil is double filtered through a 100 mesh suction line strainer and 10 micron return line filter. The hydraulic tank is integrated into the frame. An emergency lowering valve is provided to allow the load to be lowered in the event of power loss. O-ring face seal fittings are used in all high pressure hydraulic connections.

### Masts

Yale Simplex LFL (Limited Free Lift) and Triplex FFL (Full Free Lift) masts are available. The mast features pre-lubed and sealed full radius load rollers that resist forward, rearward and lateral forces. Side-thrust wear pads allow for periodic adjustment for lateral clearances. The rolled mast channels are made of high strength steel to provide resistance to flaring of the mast channel. Wide (2.03m) hook-type carriages are standard equipment, providing great visibility and the fitting of a wide variety of forks and attachments. Pin-type carriages are also available.

### Options

- Powertrain protection system with engine shutdown
- Premium monitoring package
- Internal sideshift and integral

## VX Series

Models: GDP/GLP 80VX6, 80VX9, 90VX6

sideshifting fork positioner

- Accumulator
- Keyless start (with auxillary key switch)
- LED brake and reversing lights
- Headlights and rear drive lights with halogen bulbs
- Headlights and rear drive lights with LED bulbs
- Traction speed limiter
- Return-to-set tilt
- Integral operator's cab
- Swivel full suspension vinyl and cloth seats
- Foot directional control pedal
- Impact monitor
- Operator password
- Alarm - reverse actuated 82-102 dB(A) - self adjusting
- LED amber strobe light - keyswitch activated
- Solid and radial tyres
- 4 function (2 aux.) hydraulic control valve
- 5° forward/6° backward tilt
- Fire extinguisher
- Lifting eyes





**Yale** 

**NACCO Materials Handling Limited**  
trading as **Yale Europe Materials Handling**  
Flagship House, Reading Road North, Fleet, Hampshire GU51 4WD,  
United Kingdom.  
Tel: + 44 (0) 1252 770700 Fax: + 44 (0) 1252 770784  
[www.yale-forklifts.eu](http://www.yale-forklifts.eu)

Country of Registration: England. Company Registration Number: 02636775



**Safety.** This truck conforms to the current EU requirements. Specification is subject to change without notice.

Yale, VERACITOR and  are registered trademarks. "PEOPLE, PRODUCTS, PRODUCTIVITY", PREMIER, Hi-Vis, and CSS are trademarks in the United States and certain other jurisdictions. MATERIALS HANDLING CENTRAL and MATERIAL HANDLING CENTRAL are Service Marks in the United States and certain other jurisdictions.  is a Registered Copyright.  
© Yale Europe Materials Handling 2013. All rights reserved.

Truck shown with optional equipment

Printed in The United Kingdom (0213HG) EN  
Publication part no. 258725914 Rev.07